

*Packing Instructions For
Fast Fold Screen
Surfaces*

*Da-Tex, Da-Mat, Pearlescent,
Cinema Vision, and Dual Vision*



The **POWER** *In* _____
PRESENTATION PRODUCTS



DA-LITE SCREEN COMPANY, INC.

3100 North Detroit Street
Post Office Box 137
Warsaw, Indiana 46581-0137
Phone: 219/267-8101
800-622-3737
Fax: 219/267-7804
[http:// www.da-lite.com](http://www.da-lite.com)
e-mail: info@da-lite.com

FOLDING INSTRUCTIONS

Please follow the steps as outlined below when folding the screen material for packing:

1. Make sure the surface does not come in contact with a painted, varnished, plastic, or dyed surface or object. Prolonged contact with any one of these materials could cause a chemical reaction and compromise the screen's physical or optical quality. This can be accomplished by laying a white clean cotton fabric or paper (slightly larger than the screen size) on a flat surface prior to folding the screen.
2. With the dull side up on Da-Tex, Dual Vision, and Da-Mat and the pearlescent side up on Pearlescent and Cinema Vision fold the fabric in half from top to bottom. (A 7.5' x 10' screen is now 3.75' x 10'.) **Make sure that the screen never comes in contact with the black binding, grommets or snap buttons. Please note that for this to happen, one must make sure all folds subsequent to the first fold stop short of black binding material as illustrated below.**

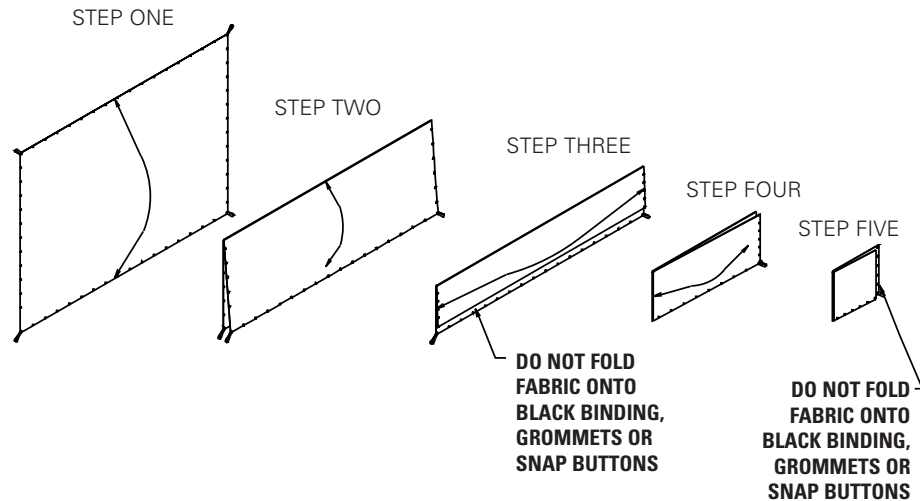

3. Place clean tissue paper or white 100% cotton material between the folds.
4. If the folded area is more than 3 feet wide (which is the case in the above example), then continue to fold until the folded area is equal to or smaller than 3 feet wide. **Please remember that all folds subsequent to the first fold must stop short of the black binding material to keep the viewing area away from it and the snap buttons as illustrated above.**

5. Once the top to bottom folding is completed, fold from left to right and continue folding until the folded area is small enough to fit into the vinyl pouch. **Please note that the final fold must stop short of the black binding material to keep the viewing area away from it and the snap buttons as illustrated.**

STORAGE AND CLEANING

STORAGE

1. The screen surface must be stored in its pouch when not in use to prevent damage and discoloration.
2. While in storage, avoid extreme temperature conditions. If surface becomes sticky, see cleaning instructions below.
3. If stored at temperatures far below room temperature, allow the screen to warm up to room temperature before unfolding. This will ensure the film is being handled in its most flexible state and will prevent surface cracks.

CLEANING

Da-Tex, Dual Vision, and Da-Mat surfaces can be cleaned as follows:

Using a white clean cloth (100% cotton preferred) that is dampened with clear water, gently wipe the area in one direction. Do not use a circular motion. Using a dry 100% cotton cloth, wipe dry after each cleaning session. To clean a stubborn stain or a sticky surface, use denatured alcohol (methanol or methyl alcohol) following the same procedure as for water. For extremely stubborn stains, use V M & P, Naphtha or Super Naphtha and follow the same procedure as for water.