



ELECTROL



**INSTRUCTION BOOK FOR
DUAL MASKING ELECTROL**

DA-LITE SCREEN COMPANY, INC.

3100 North Detroit Street
Post Office Box 137
Warsaw, Indiana 46581-0137
Phone: 219/267-8101
800-622-3737
Fax: 219/267-7804
[http:// www.da-lite.com](http://www.da-lite.com)
e-mail: info@da-lite.com

PRE-INSTALLATION

1. Carefully unpack screen.
2. Make sure to recheck measurements of screen location before installation.

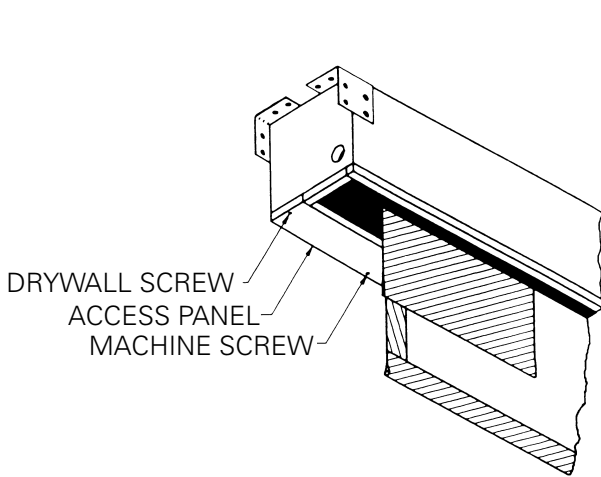

FIGURE 1

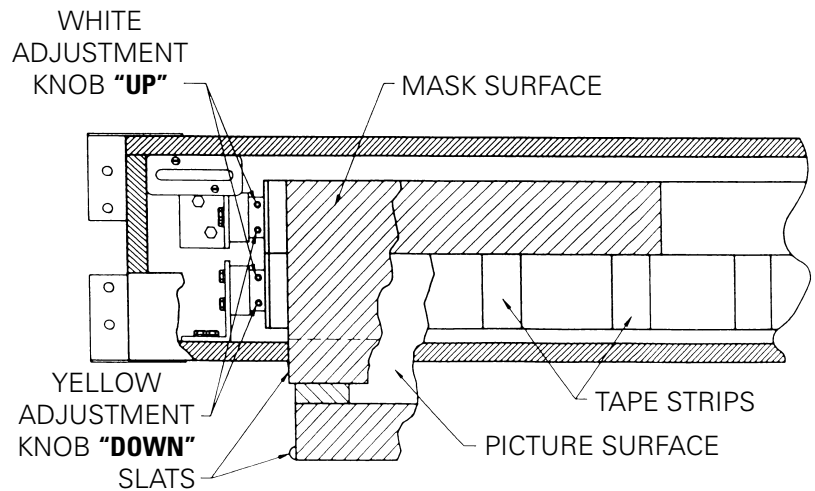

FIGURE 2

INSTALLATION

1. Install screen by raising unit into position between joists at one end only. Install one lag screw in each mounting bracket.
2. Level unit lengthwise with a carpenter's level and plum level. Secure opposite end.

CAUTION! Do not seal in until screen has been secured in position and properly tested for satisfactory operation.

3. Detach access panel by removing screws, see figure 1.
4. Remove junction box cover plate.

5. Install electrical hook up that applies to your unit. Make sure to review your electrical installation checklist and wiring diagrams (included) for either 120 volt switch, 220/240 volt switch or DRC low voltage control.

NOTE: Screen has been internal wired at Da-Lite. Wiring designated "external" is completed by installer conforming to local and national codes.

CAUTION! DO NOT CUT TAPE ON FABRIC WITH KNIFE OR ANY SHARP TOOL. REMOVE BY HAND.

6. Carefully remove wood boards securing mask surface to case.
7. Carefully remove tape strips securing picture surface around roller. Slats should move freely (Fig. 2).
8. Test installation by carefully running picture and mask surfaces up and down several times. Be prepared to stop screen.
9. Run the picture surface upward. When the picture surface is fully up the limit switch (in the motor) is tripped and the motor shuts off.
10. Test the mask surface the same as testing the picture surface.
11. Check for satisfactory condition by operating screen a few times. Reinstall access panel.

CAUTION! Excessive continuous operation may cause overheating.

SCREEN ADJUSTMENT

CAUTION! THE MASK SHOULD NOT BE FIELD ADJUSTED FOR MORE OR LESS DROP.

Surface travel is stopped automatically in the fully opened and closed positions by limit switches that are properly adjusted at Da-Lite. Should it be necessary to adjust for more or less drop of picture, proceed in the following manner:

NOTE: Use a screw driver or allen wrench to make adjustments.

MORE SCREEN DROP

1. Remove access panel (Fig. 1).
2. Place operating switch in "down" position.
3. When the screen stops, turn the yellow "down" limit knob (Fig. 2) one-quarter turn counterclockwise. Test by raising picture surface approximately two feet, then lower again. Repeat until desired picture surface position is attained.

NOTE: Must leave 1-1/2 wraps of fabric on roller!

4. Replace access panel.

LESS SCREEN DROP

1. Remove access panel. (Fig. 1).
2. Raise picture surface approximately two feet above desired level.
3. Place operating switch in "off" position.
4. Turn the yellow "down" limit knob (Fig. 2) one-quarter turn clockwise. Test by raising picture surface approximately two feet, then lower again. Repeat until desired picture surface position is attained.
5. Replace access panel.

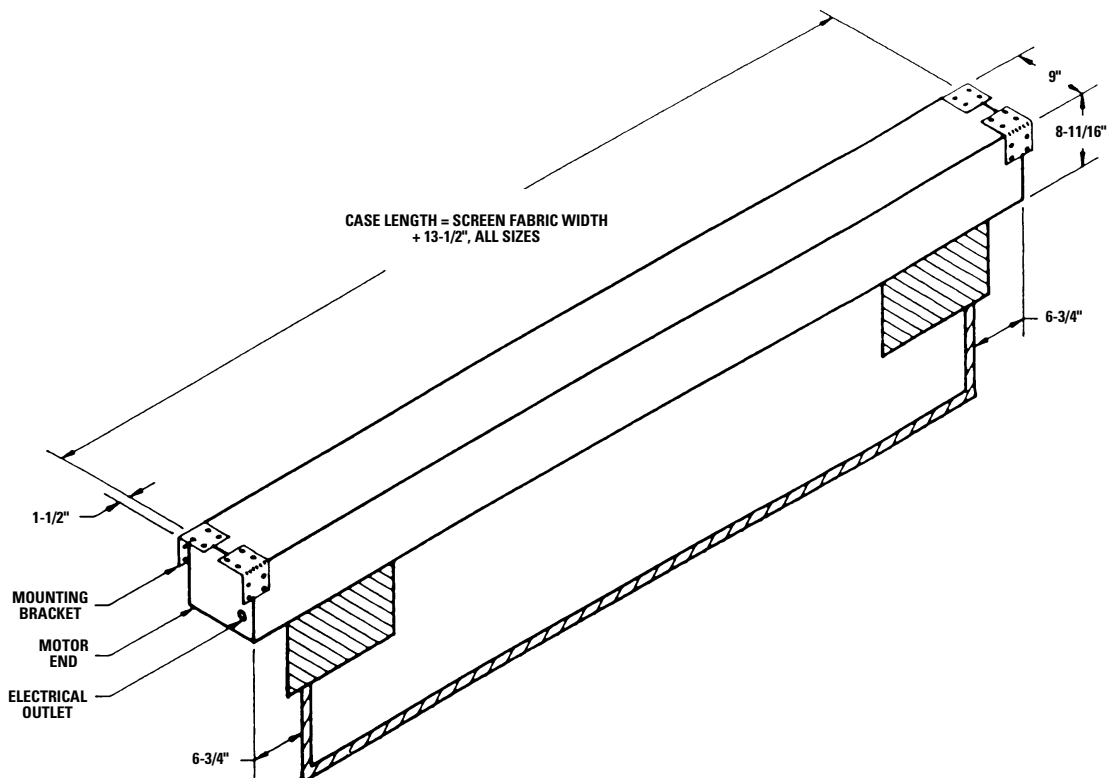

DUAL MASKING ELECTROL INSTRUCTIONS

120V WIRING DIAGRAM

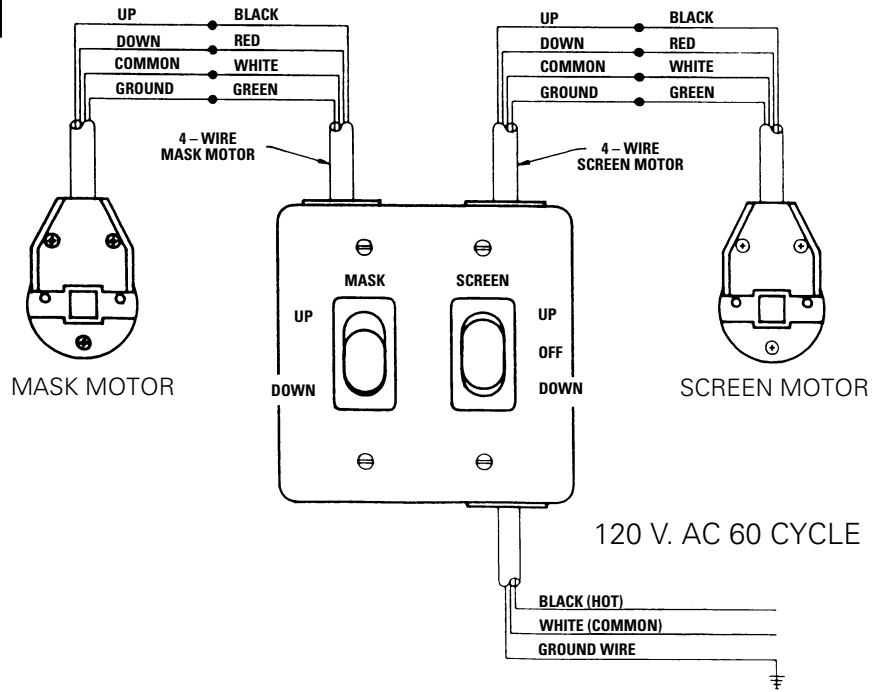

220 / 240V WIRING DIAGRAM

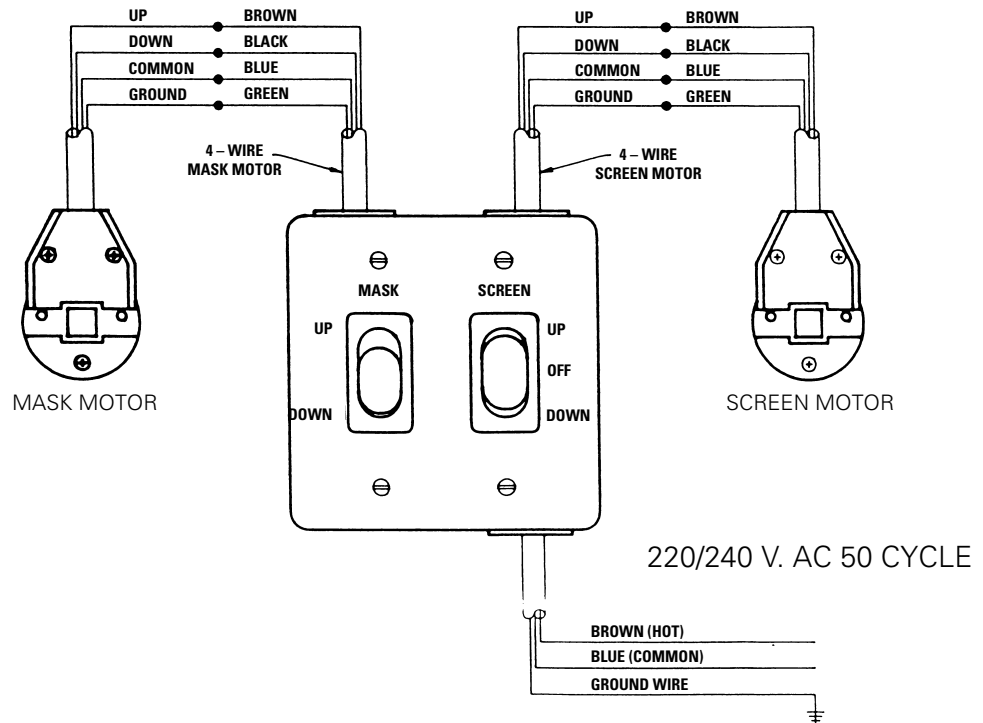

SUGGESTED METHODS OF INSTALLATION

METHOD A

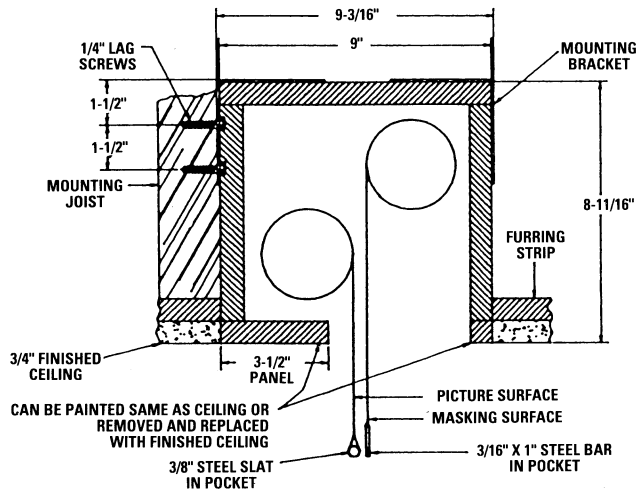

Offset mounting, recessed above ceiling. For plaster, dry wall, tile or paneling. Bottom of case painted same finish as ceiling.

METHOD B

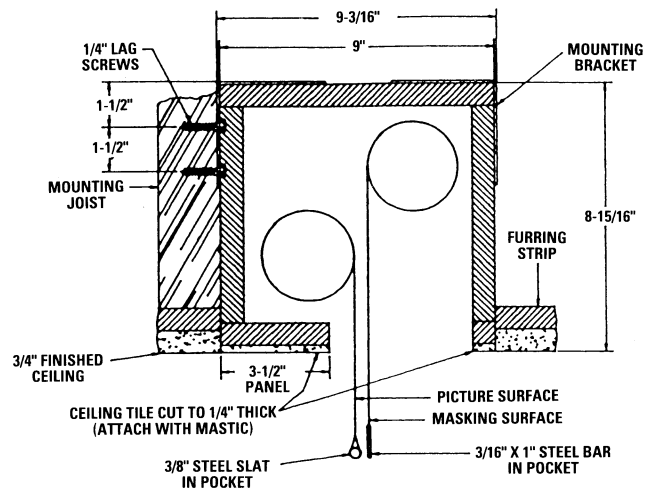

Offset mounting, recessed above ceiling. May be adapted for 3/4" ceiling, but cut to 1/4" thick under screen case and panel.

NOTE:

MUST MARK HOLE LOCATION OF SCREWS IN 3-1/2" PANEL FOR REMOVAL, IF COVERING WITH TILE.

METHOD C

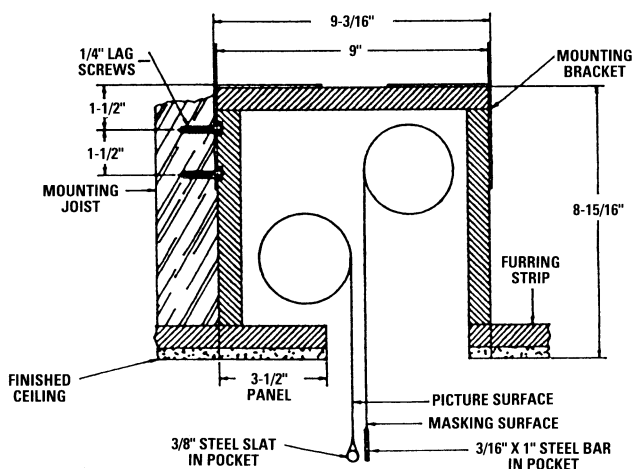

Offset mounting, recessed above ceiling. May be adapted for 1/4" paneling for ceiling.

METHOD D

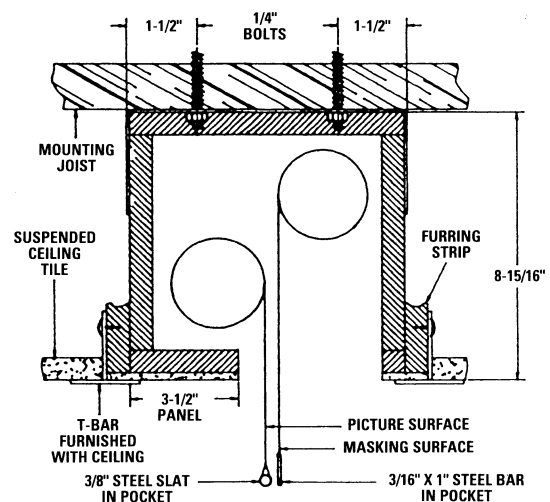

Flush mounting, recessed above ceiling. For use with dropped ceiling. May also be adapted for use with acoustical or other ceiling 3/4" thick but cut to 1/4" thick under screen case and panel.

TROUBLESHOOTING

SYMPTOM	CAUSE	SOLUTION
<p>1. Screen or mask will not operate or will not go "down."</p> <p>Motor does not hum.</p> <p>Motor hums.</p>	<p>(a) Blown facility fuse.</p> <p>(b) Tripped facility circuit breaker.</p> <p>(c) No power to operating switch or junction box.</p> <p>Power at junction box</p> <p>(d) Thermal overload tripped.</p> <p>(e) Broken wire in the "down" position.</p> <p>(f) Defective motor, limit switch or capacitor.</p> <p>(g) Temporary binding.</p> <p>(h) Capacitor burned out.</p>	<p>(a) Replace facility fuse.</p> <p>(b) Reset facility circuit breaker.</p> <p>(c) Check above. Tighten all loose wire connections. Recheck wiring. See installation instructions.</p> <p>"Down" Position</p> <p>Check for power across black and white leads.</p> <p>(d) Let motor cool down for 15 minutes. Try again.</p> <p>(e) Check for continuity.</p> <p>(f) Replace motor assembly. NOTE: Motor is a sealed assembly.</p> <p>(g) With power "off," turn roller by hand to free binding.</p> <p>(h) Replace motor assembly.</p>
<p>2. Screen or mask will not move upward.</p> <p>Motor does not hum.</p> <p>Motor hums.</p>	<p>(a) Blown facility fuse.</p> <p>(b) Tripped facility circuit breaker.</p> <p>(c) No power to operating switch or junction box.</p> <p>Power at junction box</p> <p>(d) Thermal overload tripped.</p> <p>(e) Broken wire in the "down" position.</p> <p>(f) Defective motor, limit switch or capacitor.</p> <p>(g) Temporary binding.</p> <p>(h) Capacitor burned out.</p>	<p>(a) Replace facility fuse.</p> <p>(b) Reset facility circuit breaker.</p> <p>(c) Check above. Tighten all loose wire connections. See above.</p> <p>"Up" Position</p> <p>Check for power across red and white leads.</p> <p>(d) Let motor cool down for 15 minutes. Try again.</p> <p>(e) Check for continuity.</p> <p>(f) Replace motor assembly. NOTE: Motor is a sealed assembly.</p> <p>(g) With power "off," turn roller by hand to free binding.</p> <p>(h) Replace motor assembly.</p>

TROUBLESHOOTING

SYMPTOM	CAUSE	SOLUTION
3. "Down" limit switch incorrect.	(a) "Down" limit switch out of adjustment.	(a) See installation instructions.
4. Noise. NOTE: Screen will operate with a low-pitched hum.	(a) Squeaking, rubber end plug rubbing on motor. (b) Grinding. Foreign object in screen rubbing on roller or fabric. (c) Gear noise	(a) Center roller in case. (b) Remove foreign object. (c) Replace motor assembly.
5. Coasting.	(a) Defective brake.	(a) Replace motor assembly.
6. Roller displaced from mounting brackets.	(a) Pin end slipped out of nylon bearing.	(a) Remove pin end mounting. Realign motor in tube. Reattach pin end.
7. Fabric hangs crooked.	(a) Screen not installed properly. (b) Fabric has backed up inside case. (c) Fabric is damaged.	(a) Check for level and plumb. (b) Adjust "down" limit switch slowly until roller is exposed and wrinkle comes out, then adjust for proper drop. (c) Replace fabric.

LIMITED ONE YEAR WARRANTY ON DA-LITE PROJECTION SCREENS

Da-Lite Screen Company, Inc. warrants its screens to the original purchaser only, to be free from defects in materials and workmanship for a period of one (1) year from the date of purchase by the original purchaser provided they are properly operated according to Da-Lite's instructions and are not damaged due to improper handling or treatment after shipment from the factory.

This warranty does not apply to equipment showing evidence of misuse, abuse, or accidental damage, or which has been tampered with or repaired by person other than authorized Da-Lite personnel.

Da-Lite's sole obligation under this warranty shall be to repair or to replace (at Da-Lite's option) the defective part of the merchandise. Returns for service should be made to your Da-Lite dealer. If it is necessary for the dealer to return the screen or part to Da-Lite, transportation expenses to and from Da-Lite are payable by the purchaser and Da-Lite is not responsible for damage in shipment. To protect yourself against damage or loss in transit, insure the product and prepay all transportation expenses.

THIS WARRANTY IS IN LIEU OF ALL OTHER WARRANTIES, EXPRESS OR IMPLIED, INCLUDING WARRANTIES AS TO FITNESS FOR USE AND MERCHANTABILITY. Any implied warranties of fitness for use, or merchantability, that may be mandated by statute or rule of law are limited to the one (1) year warranty period. This warranty gives you specific legal rights, and you may also have other rights which vary from state-to-state. NO LIABILITY IS ASSUMED FOR EXPENSES OR DAMAGES RESULTING FROM INTERRUPTION IN OPERATION OF EQUIPMENT, OR FOR INCIDENTAL, DIRECT, OR CONSEQUENTIAL DAMAGES OF ANY NATURE.

In the event that there is a defect in materials or workmanship of a Da-Lite Screen, you may contact our Customer Service Department at P.O. Box 137, Warsaw, Indiana 46581-0137 (219/267-8101) Toll Free (800/622-3737).

IMPORTANT: THIS WARRANTY SHALL NOT BE VALID AND DA-LITE SHALL NOT BE BOUND BY THIS WARRANTY IF THE PRODUCT IS NOT OPERATED IN ACCORDANCE WITH DA-LITE'S WRITTEN INSTRUCTIONS.

Keep your sales receipt to prove the date of purchase and your original ownership.

