

**MODEL C
EXCLUSIVE FEATURES**

- Choice of Glass Beaded or Non-Gloss Matte White Picture Surfaces
- Easily Installed
- Multi-Purpose End Caps Form Sturdy Brackets for Wall/Ceiling Installation
- Aluminum Slat Saddle Distributes Uniform Tension on Picture Surface
- Heavy Duty Grooved Metal Roller Assures Permanent Fastening of Picture Surface
- Nylon and Ball Bearing Roller Mounting
- Handsome, Rugged, Enamel Steel Case
- Floor Stand Accessory (optional at extra cost)

**TO USE WITH
PORTABLE FLOOR STAND**

NOTE: CAN ONLY BE USED WITH FLOOR MODEL C. WALL WILL NOT OPERATE CORRECTLY.

1. Assemble stand according to instructions.
2. Lay screen in cradle of stand with pull bail up.
3. Lift surface by pull bail and hook pull bail over gooseneck of elevating support.
4. Raise upper handle of elevating support until it locks in top position.
5. Raise lower handle of elevating support until full picture area is obtained and locked in position. No stretching, no straining.
6. Stand may be placed on table if extra height is needed.

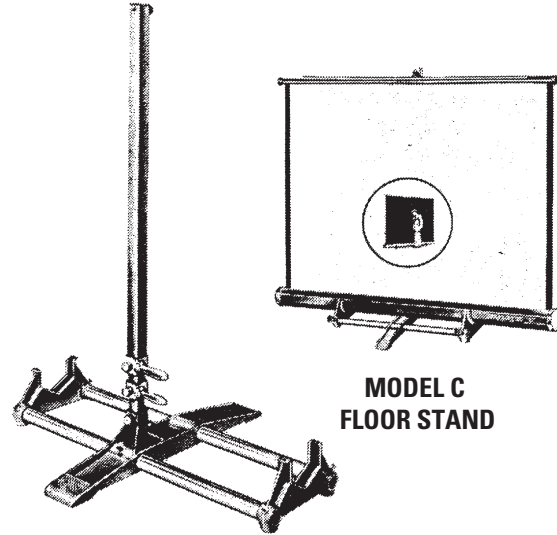

**MODEL C
FLOOR STAND**

**HANGING BRACKETS
(Optional at extra cost)**

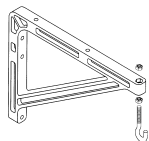

No. 11 Wall Bracket
Non-Adjustable permits screen to extend 10" or 14" from wall.

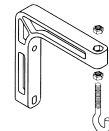

No. 6 Wall Bracket
Non-Adjustable permits screen to extend 6" from wall.

**DA-LITE IS MORE
THAN PROJECTION SCREENS**

Da-Lite Tripod, Wall & Ceiling and Electric Screens

Da-Lite Overhead and Opaque Projectors

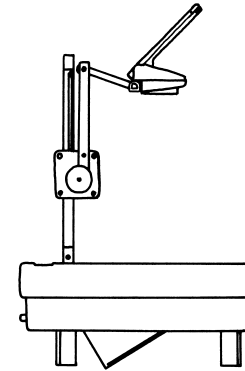
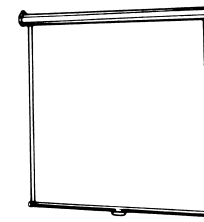

Da-Lite Model 5000 Portable

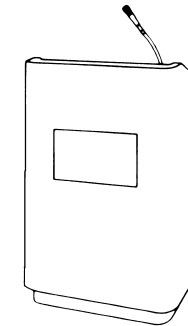

Da-Lite Lecterns Communications Cabinets



Da-Lite Project-O-Stands and Easels

46422 Rev. 3/97



**HEAVY DUTY
WALL/CEILING
PROJECTION SCREEN**



**OPERATING INSTRUCTIONS
FOR**

MODEL C

DA-LITE SCREEN COMPANY, INC.
3100 North Detroit Street
Post Office Box 137
Warsaw, IN 46581-0137
Phone: 219/267-8101
800-622-3737
Fax: 219/267-7804
[http:// www.da-lite.com](http://www.da-lite.com)
e-mail: info@da-lite.com

YOU HAVE MADE A WISE SELECTION...

in choosing a Da-Lite projection screen, designed and engineered to produce the sharpest, most pleasing pictures with maximum convenience.

WALL MOUNTING

1. Select fasteners of proper type for wall or ceiling involved.
2. Insert fasteners through proper openings provided in back side of end caps.
3. Attach screen securely to studding or other solid surface - never to plaster only.
4. MAKE SURE SCREEN IS MOUNTED LEVEL.

TO OPEN SCREEN

Pull down on pull bail until desired picture area is obtained. Lock into position as on a window shade. Be sure surface is locked before releasing.

CEILING MOUNTING

1. Heavy screw hooks may be installed into wood joists. Other types of hooks or chain may be used for other ceilings or for stage installations.
2. Insert hooks or chain through proper openings provided in sides of end caps. Screen must hang so that flat back of case is perpendicular to floor.
3. MAKE SURE SCREEN IS MOUNTED LEVEL.

PRECISION SEAMING

Large screens will have one or more horizontal seams. Seams are standard and necessary in large size screens since surfaces are limited to the available fabric size.

Da-Lite Perma-Sealed seams are made by butting carefully matched edges of two panels together and fastening with special tape that is sealed to the reverse side. These seams are guaranteed not to separate. Seams in a picture surface should not be construed as patched or defective. In use, the seam will be virtually invisible in the projected picture.

TO RE-ROLL YOUR PICTURE SURFACE

The Model C operates on the same principle as a window shade. Pull down about 6 inches to disengage the locking pawl and start the fabric up firmly and quickly.

Large picture surfaces are heavy and will start up too slowly to prevent the locking pawl from catching unless help is provided, so keep picture surface moving briskly.

Should the locking pawl catch, pull the picture surface down about 6 inches and start the surface up rapidly.

However, do not permit the picture surface to roll up uncontrolled, particularly the last few feet. Allowing the bottom slat to strike the case uncontrolled may result in severe damage to your screen. Use the cord provided for control.

PROTECT YOUR SCREEN

Before re-rolling surface into case, examine both front and back of surface to be sure they are free of foreign matter.

SUGGESTED METHODS OF INSTALLATION

