

*Instruction Book For  
Imager*



*The*  
**POWER** *In*  
**PRESENTATION PRODUCTS**



**DA-LITE SCREEN COMPANY, INC.**

3100 North Detroit Street  
Post Office Box 137  
Warsaw, Indiana 46581-0137  
Phone: 219/267-8101  
800-622-3737  
Fax: 219/267-7804  
[http:// www.da-lite.com](http://www.da-lite.com)  
e-mail: [info@da-lite.com](mailto:info@da-lite.com)

## SETTING UP YOUR SCREEN

**TOOLS REQUIRED:**      **Phillips Screwdriver**  
                                 **Carpenter's Level**  
                                 **Tape Measure**

### FRAME ASSEMBLY

1. Place the four frame pieces on a clean floor. The sides with the Velcro should face up.
2. Align the corner brackets with the slots in the frame and slide the frame pieces together (Figure 1). When assembling the last frame piece, slide both ends together at the same time to avoid binding the corner brackets.
3. Push and hold the corners together and tighten the four screws at each corner. Do not over-tighten the screws.

### ATTACH THE VIEWING SURFACE

1. Place the screen on the back of the frame assembly. Start at the top of the frame and attach the screen from the center working towards the sides. Look at the screen from the viewing side to make sure the Velcro is not visible.
2. Attach the rest of the screen in the following order. Bottom, left side, right side. Stretch the screen as necessary to remove any wrinkles.

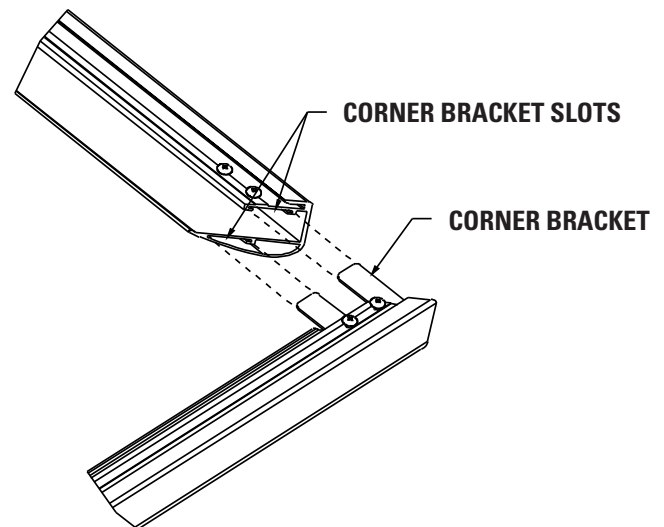
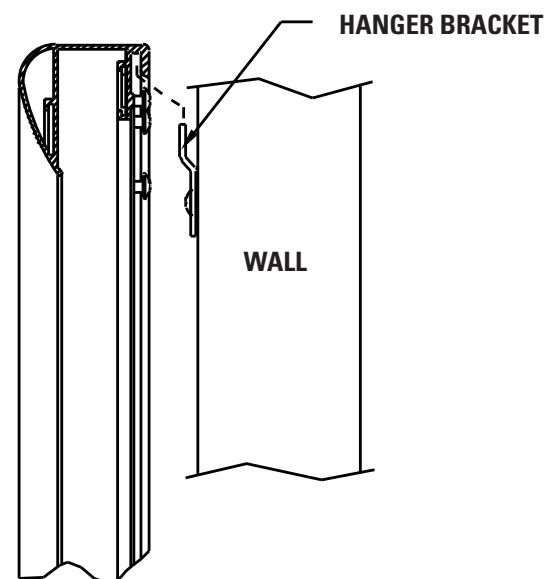

**FIGURE 1**

## SUGGESTED METHODS OF INSTALLATION

### MOUNTING SCREEN TO THE WALL

1. Mount 1 or 2 hanger brackets as provided into the wall studs at the desired height. Use a carpenter's level to make sure the brackets are level. The top of the screen frame will be 1/8" above the top of the bracket when mounted. You will need at least 5/8" clearance above the bracket to hang the screen.
2. After the hanger brackets are securely fastened to the wall, hang the screen assembly on the brackets as shown in figure 2.



**FIGURE 2**

**LIMITED ONE YEAR WARRANTY ON DA-LITE PROJECTION SCREENS**

Da-Lite Screen Company, Inc. warrants its screens to the original purchaser only, to be free from defects in materials and workmanship for a period of one (1) year from the date of purchase by the original purchaser provided they are properly operated according to Da-Lite's instructions and are not damaged due to improper handling or treatment after shipment from the factory.

This warranty does not apply to equipment showing evidence of misuse, abuse, or accidental damage, or which has been tampered with or repaired by person other than authorized Da-Lite personnel.

Da-Lite's sole obligation under this warranty shall be to repair or to replace (at Da-Lite's option) the defective part of the merchandise. Returns for service should be made to your Da-Lite dealer. If it is necessary for the dealer to return the screen or part to Da-Lite, transportation expenses to and from Da-Lite are payable by the purchaser and Da-Lite is not responsible for damage in shipment. To protect yourself against damage or loss in transit, insure the product and prepay all transportation expenses.

THIS WARRANTY IS IN LIEU OF ALL OTHER WARRANTIES, EXPRESS OR IMPLIED, INCLUDING WARRANTIES AS TO FITNESS FOR USE AND MERCHANTABILITY. Any implied warranties of fitness for use, or merchantability, that may be mandated by statute or rule of law are limited to the one (1) year warranty period. This warranty gives you specific legal rights, and you may also have other rights which vary from state-to-state. NO LIABILITY IS ASSUMED FOR EXPENSES OR DAMAGES RESULTING FROM INTERRUPTION IN OPERATION OF EQUIPMENT, OR FOR INCIDENTAL, DIRECT, OR CONSEQUENTIAL DAMAGES OF ANY NATURE.

In the event that there is a defect in materials or workmanship of a Da-Lite Screen, you may contact our Customer Service Department at P.O. Box 137, Warsaw, Indiana 46581-0137 (219/267-8101) Toll Free (800/622-3737).

**IMPORTANT:** THIS WARRANTY SHALL NOT BE VALID AND DA-LITE SHALL NOT BE BOUND BY THIS WARRANTY IF THE PRODUCT IS NOT OPERATED IN ACCORDANCE WITH DA-LITE'S WRITTEN INSTRUCTIONS.

Keep your sales receipt to prove the date of purchase and your original ownership.

