



DA-SNAP

Wall-Mounted Projection Screen

SPECIFICATION DATA

DA-LITE SCREEN COMPANY, INC.
3100 North Detroit Street
Post Office Box 137
Warsaw, Indiana 46581-0137
Phone: 219/267-8101
800-622-3737
Fax: 219/267-7804
http:// www.da-lite.com
e-mail: info@da-lite.com

SUGGESTED SPECIFICATIONS: _____ projection screen(s), _____ (H) x _____ (W), wall mounted type. To have flexible screen surface of Da-Mat, Cinema Vision, Pearlescent, High Power, Da-Tex or Dual Vision. All screen surfaces are fire and mildew resistant. Screen surface standard with reinforced black webbing on all four sides and will attach to frame with metal snaps, Velcro optional. Frame will conceal snaps and webbing. Screen frame will be 1½" square matte black powder coated 6063-T5 aluminum with .062 walls. Walls will be ribbed for strength and light weight. Frame will be slip-jointed at corners and side sections. Corners will be welded and connecting plugs are riveted together. Standard wall-mounting brackets will be included.

All DA-MAT, CINEMA VISION, PEARLESCENT, DA-TEX, and DUAL VISION surfaces are seamless up to 12' high. Audio Vision surface is seamless up to 6 feet. DA-SNAP is available in front and rear screens up to 20' high and 50' wide.

VIDEO FORMAT DIMENSIONS

Viewing Area		Nominal Diagonal		Overall Dimensions H x W		Approx. Ship. Wt.	
H x W	Cm	In.	Cm	In.	Cm	Lbs.	Kg
36" x 48"	91 x 122	60"	152	39" x 51"	99 x 129	19	8.62
43" x 57-1/2"	109 x 145	72"	183	46" x 60-1/2"	117 x 154	22	9.98
50-1/2" x 67"	128 x 170	84"	213	53-1/2" x 70"	136 x 178	24	10.89
57-1/2" x 77"	146 x 196	96"	244	60-1/2" x 80"	154 x 203	28	12.70
60" x 80"	152 x 203	100"	254	63" x 83"	160 x 211	30	13.61
72" x 96"	183 x 244	120"	305	75" x 99"	191 x 251	36	16.33
90" x 120"	229 x 305	150"	381	93" x 123"	236 x 312	44	19.96
108" x 144"	274 x 366	180"	475	111" x 147"	282 x 373	50	20.87
120" x 160"	305 x 406	200"	508	123" x 163"	312 x 414	75	34.02
144" x 192"	366 x 488	240"	610	147" x 195"	373 x 495	90	40.82

HDTV FORMAT DIMENSIONS

Viewing Area		Nominal Diagonal		Overall Dimensions H x W		Approx. Ship. Wt.	
H x W	Cm	In.	Cm	In.	Cm	Lbs.	Kg
52" x 92"	132 x 234	106"	269	55" x 95"	140 x 241	30	13.61
58" x 104"	147 x 264	119"	302	61" x 107"	155 x 272	32	14.52
65" x 116"	165 x 295	133"	338	68" x 119"	172 x 302	34	15.42
78" x 139"	198 x 353	159"	404	81" x 142"	206 x 361	40	18.14

Overall dimensions ± 1/4".

Specifications subject to change without notice.

WHEN ORDERING, MARK APPROPRIATE SELECTIONS:

Select size from chart above.

Select viewing surface:

- Da-Mat
- Cinema Vision
- Pearlescent
- High Power
- Da-Tex (Rear Projection)
- Dual Vision

Options:

- Manual Keystone Eliminator
- Metal Snaps
- Velcro® Attachment
- Pro-Trim

Pro-Trim Light Absorbing Viewing System (LAV) is a fabric covering that aesthetically enhances the appearance of the installation. Pro-Trim provides a stylish masked border while absorbing the light that surrounds the viewing area.

Project:	_____
Architect:	_____
Phone:	_____
Contractor:	_____
Phone:	_____
Supervisor:	_____
Phone:	_____
Date:	_____
Revised:	_____

**DA-SNAP
SHOWN FROM BACK SIDE**

VIEWING SIDE

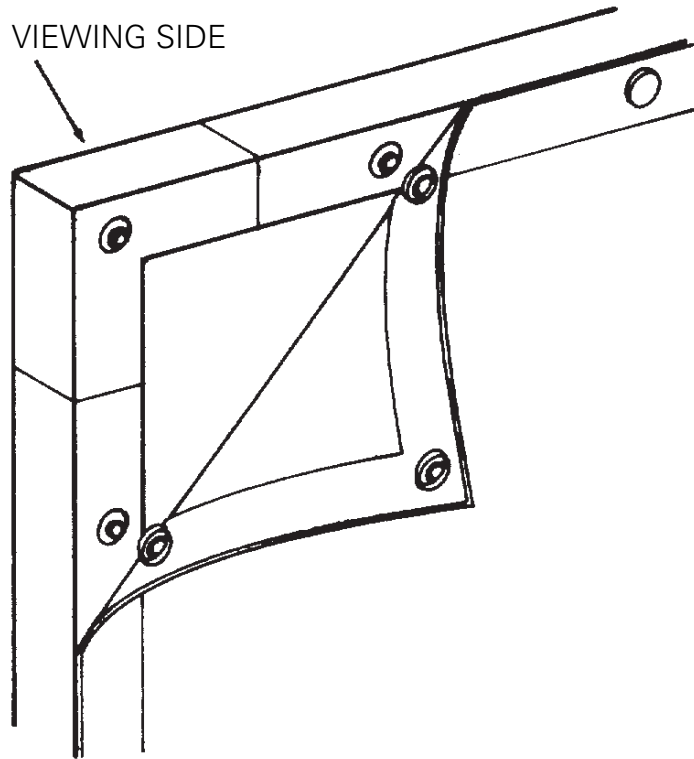

**DA-SNAP
WALL MOUNT**

VIEWING SIDE

