

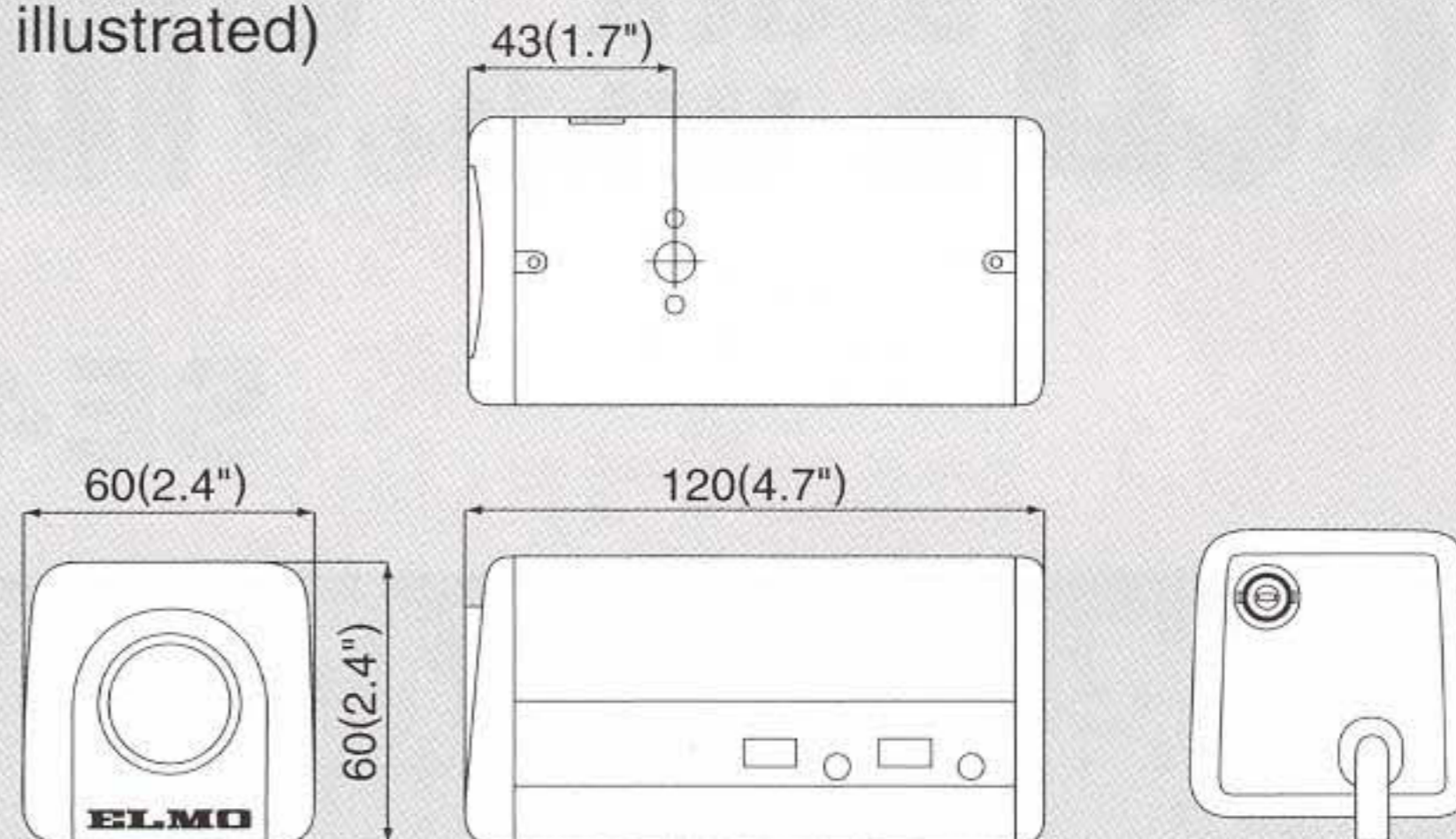

(with an optional lens)

PROFILE

(SE420 illustrated)



All dimensions in mm

SPECIFICATIONS

Power	AC24V±10%, 60Hz±0.5Hz
Power consumption	Approx. 4.3W
Pick-up device	1/2" Black & White Interline Transfer CCD
Effective picture element	768(H)×494(V)
Scanning area	6.45mm(H)×4.84mm(V)
Scanning system	2:1 interlaced
Scanning frequency	15.75kHz(H), 60Hz(V)
Sync. system	Line-lock/Internal/External
Resolution	More than 570TV(H) lines
S/N ratio	More than 50dB
Minimum illumination	0.06 lx (F1.2 under incandescent lamp w/Sens-up sw. on)
AGC	Built-in
Sens-up	Provided (Factory-set at OFF)
Backlight compensation	Provided (Factory-set at OFF)
AES (Automatic Electronic Shutter)	Provided (Factory-set at OFF)
Electronic shutter	8 steps (1/60~1/10,000 sec)
Output signal	VBS 1V (p-p) 75Ω, BNC Connector
External Sync. input	VBS 1V (p-p) 75Ω, BNC Connector
Auto-iris terminal	4P square connector
Power terminal	3P screw terminal
Lens mount	CS
Ambient temperature	-10°C~50°C (14°F~122°F)
Ambient humidity	30%~90%
Dimensions	60(W)×60(H)×120(D)mm (2.4×2.4×4.7in)
Weight	520g (1.17lbs)

Note : Design and specifications are subject to change without prior notice.
Dimensions and weight are approximate.

ELMO ELMO CO., LTD

6-14, Meizen-cho, Mizuho-ku,
Nagoya, 467-8567 Japan
E-mail: elmo@gix.or.jp

Distributed by

ELMO Mfg. Corp.

1478 Old Country Road,
Plainview, NY 11803-5034,
U.S.A.
Tel. 516-501-1400
Fax.516-501-0429
E-mail: elmo@elmo-corp.com
Web: www.elmo-corp.com

21720 Nordhoff Street,
Chatsworth,
CA 91311-5826,
U.S.A.
Tel. 818-346-4500
Fax.818-998-4186

ELMO Canada Mfg. Corp.

44 West Drive, Brampton,
Ontario, L6T 3T6,
Canada
Tel. 905-453-7880
Fax.905-453-2391
E-mail: elmo.canada@cimtegration.com

ELMO (Europe) G.m.b.H.

Karl-Rudolf-Str. 178,
40215 Düsseldorf,
Germany
Tel. 0211-376051-53
Fax.0211-376630
E-mail: elmoeuropa@AOL.com