

Black & White CCD VIDEO CAMERA TEB4404

PROFILE

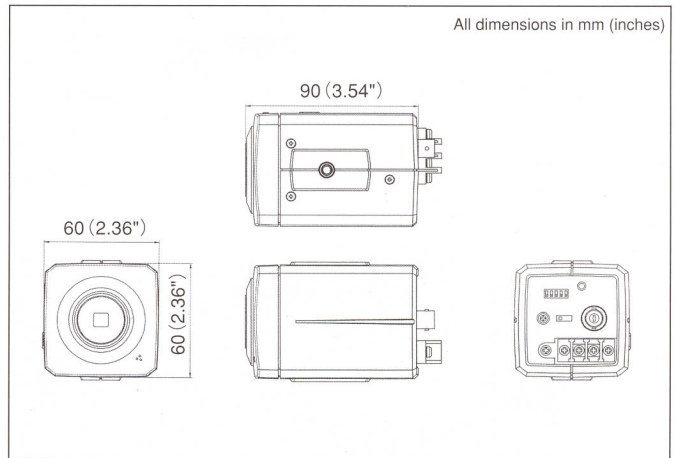

SPECIFICATIONS

Power source	AC24V/DC12V
Pick-up device	1/3" B&W interline transfer EXview HAD CCD
Effective picture element	768(H) x494(V)
TV system	EIA
Sync. system	Line-lock/Internal
Resolution	570 TV lines(H) 350 TV lines(V)
S/N ratio	50dB
Minimum illumination	0.05 lx(F1.2)
AGC switch	Built-in
Backlight compensation	Built-in
AES switch	Built-in
Iris selector	Built-in
Gamma selector	Built-in
Lens mount	CS
Video output	BNC
Lens back adjustment	Built-in
Dimensions	60x60x90mm (2.36x2.36x3.54")
Mass/weight	300g(0.66lbs)

NOTE: • Design and specifications are subject to change without prior notice.
• Dimensions and weight are approximate.

ELMO® ELMO CO., LTD.

Additional technical information is available from any of the following subsidiary companies;

ELMO Mfg. Corp.

1478 Old Country Road, Plainview, NY 11803-5034, U.S.A.
Tel. 516-501-1400 Fax. 516-501-0429
E-mail: elmo@elmousa.com
Web: <http://www.elmousa.com>

ELMO Canada Mfg. Corp.

44 West Drive, Brampton, Ontario, L6T 3T6, Canada
Tel. 905-453-7880 Fax. 905-453-2391
E-mail: info@elmocanada.com
Web: <http://www.elmocanada.com>

6-14, Meizen-cho, Mizuho-ku,
Nagoya, 467-8567 Japan
E-mail: elmo@gix.or.jp

Distributed by

ELMO (Europe) G.m.b.H.

Neanderstr 18, 40233 Düsseldorf, Germany
Tel. 0211-376051-53 Fax. 0211-376630
E-mail: elmo@elmo.de
Web: <http://www.elmo.de/>